

# BABYMINDER

## Horizontal Infant Nappy Changing Table

Installing a Babyminder changing station provides parents with a safe, convenient and hygienic changing facility in away from home locations and is now, considered to be of equal importance as the provision of other essential facilities. The Babyminder is available in both vertical and horizontal options to fit in with the space requirements offered in a public restroom. The ergonomically designed station with a safety belt ensures that the user's child will be comfortable and safe during their changing experience. The unit also comes with moulded bag hangers to assist the user during changing and a surface sanitizer dispenser can be used to sanitize the unit before each use.

### SPECIFICATIONS

- Dimensions:  
900mm x 560mm x 120mm
- Opening angle:  
87° - slight tint towel

### SCHEMATIC

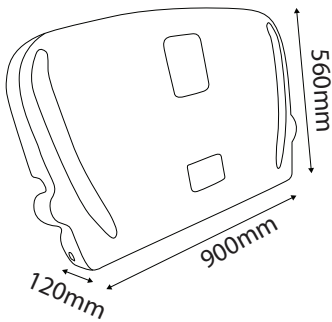

### BENEFITS

- Available in horizontal and vertical options
- Integral moulded bag hooks
- Surface sanitizer available
- Branding option

### AVAILABLE OPTIONS



Horizontal



Vertical



### CONTACT DETAILS

Cell: +27(0) 81 431 2625  
E-mail: philclassic@lantic.net